

A Portable Design of a Maize Drying Machine

Daniel Afriyie¹, Joel Akorli², Kwame Boadi³, Settor Amediku⁴, Nana Berko⁵

Engineering Department, Ashesi University

¹ Electrical Engineering Department; daniel.afriyie@ashesi.edu.gh

² Electrical Engineering Department; joel.akorli@ashesi.edu.gh

³ Mechanical Engineering Department; kwame.boadi@ashesi.edu.gh

⁴ Electrical Engineering Department; settor.amediku@ashesi.edu.gh

⁵ Electrical Engineering Department; nana.berko@ashesi.edu.gh

Abstract - Most Ghanaian maize farmers incur losses in their business. This is due to the burden that comes with post-harvest grain management. The inability of the farmers to dry these grains effectively leads to its spoilage. Maize harvested in the first planting season of maize is susceptible to destruction by weevils and other insects due to the high moisture content. To prevent the problem of post-harvest losses in the maize farming business, a maize drying machine is designed to effectively dry it before storing the grains. This paper concentrates on the calculations, design processes and procedures on specific nature of chosen design parts. The machine makes use of an induction motor that is controlled by an electrical control unit to continuously stir the grains. A blower with the necessary heating element is used to supply the grains with air. Also, there is a temperature and humidity sensor at the bottom of the machine to detect if the maize is dried. The design prevents overheating of the grains during the drying process, and reduces the manpower expended by the farmer.

Keywords - Direct On-Line, Moisture Content, Post-Harvest Losses.

1. Introduction

Maize is a high value crop that serves as source of food, employment, as well as raw materials for many industries. It is a versatile crop that can be used for many purposes. In some places, especially Africa, it is well known for its medicinal purposes. The leaves, cob, grains, and stalk can be used in the production of high-quality non-food products [1]. In some countries, maize is used as livestock feed. Though maize is a very essential grain, its post-harvest management, especially in the first planting season, has been a problem for most farmers in the country due to the inability of the grains to effectively dry. If the crop is left out on the field to dry, it will begin to deteriorate because of the slow rate at which it dries up. For this reason, it is harvested with high moisture content, and made available for purchase, to be cooked or consumed. This has a negative effect on the farmer since he loses some profit when he sells without processing it. In this paper, the focus will be designing an appropriate machine that is able to dry the maize grains efficiently to reduce post-harvest losses faced by farmers and help to increase their income. In the simulation, the Cambridge Engineering Selector (CES) software is used for material selection, Proteus software used to simulate sensor circuits, Electrical Control Techniques Simulator (EKTS) to simulate the motor, and SolidWorks for the design and simulations of some selected body parts. The maize dryer

in this paper has a long funnel-like shape as its outlet. This design allows for more grains to be poured out of it after the drying process. There are embedded sensors to measure the temperature, and moisture content of the grains throughout the drying process. After drying, the grains move along the chamber through the funnel shaped outlet, which concentrates the dried grains to a single exit point.

2. Literature Review

In a maize drier design done at the Federal University of Technology, the manufacturers prioritized on using horizontal style of drying grains [2] as it is cheaper than the vertical or tower style. The tower style used in this paper allows for different levels of aeration as the grains are passed from one level to another. Also, the horizontal style used in the design done by the Federal University that make use of conveyor belts tends to be slow and malfunctions. The tower style used in this paper allows gravity to push the grains down in the outlet. The wet grains must be dried if the inlet air conditions are drier than the wet grain. This implies that the dampness contained in the inlet air can be taken out by raising its temperature, accordingly, expanding its capacity to eliminate moisture from the wet grain. This is an easier and more efficient method of drying the grains to prevent post-harvest losses.

In [3], Mark Angelo et al designed a humidifier-dryer machine to enhance the drying up of grains in post-harvest management. The machine is operated by a programmable microcontroller that monitors the temperature and moisture content of the grains continuously for maximum drying. However, the system does not give users feedback on the amount of moisture still accumulated in it at any given time.

Hidayat et al. have proposed a Wireless Sensor Network (WSN)-based grain drying machine for the monitoring of the humidity and temperature of grains [4]. This system can monitor the drying process more accurately and in real time and is energy efficient because its node is well equipped with a power source in the form of a battery system. Although the WSN-based grain dryer does not require wiring and can be used in most places, the problem of uniform drying is not addressed in this design.

The Academy of National Food and Strategic Reserves Administration developed a rotary drying machine that starts with grain drying quality and uses mechanical ventilation to lower moisture content to address the problem of excessive moisture in grain drying that farmers confront [5]. It can dry a lot of grain at once and has a special rotating feature. Its drying mechanism involves using the fan to move dry outdoor air into the ventilation network duct. The vent hole on the duct forces air into the chamber because of the difference in pressure, altering the grain pile's microenvironmental properties. Dry air and moist grain heat interchange each other by removing the moisture in the grain into the surrounding environment throughout this operation. This new system can rotate its chamber to aid in balancing the moisture content of the grain after the drying process. However, the entire system is bulky and cannot be easily transported to other places.

3. Design Methodology

3.1. Software Used

SolidWorks, CES, EKTS and Proteus were the software used in this project.

3.2. Design

For the design of the maize dryer, the CES software was used in the selection of the right materials for the durability of the machine. After the selection of the right materials for the body of the machine, a sketch was produced for the proposed design, and the final design was rendered in SolidWorks.

3.3 Description

The maize dryer is a rectangular like structure, that has its lid perforated to allow vapor to leave the chamber. The same top serves as the inlet of the machine. The machine has a shaft or an agitator that continuously stirs the maize inside the chamber. There is an electric motor placed at the back which is linked to the agitator through v-belt and gears to cause rotation of the shaft. This motor is powered through the control panel right under it. At the back of the main drying chamber is the blower which has been connected into the inner part of the chamber to supply heat and air for the drying process. Under the rectangular drying chamber is a small space that contains a sensing unit which provides information on temperature and moisture content level within the dryer's chamber. If the humidity content is getting closer to 0, the temperature and the humidity content of the chamber are displayed on an LCD screen placed on the top left of the front view of the machine. This will prompt the user to open the outlet to collect the dried maize.

3.4 Selection of Materials

In selecting the material for the main body of the maize dryer, the priority was to get a very hard material that has a low thermal conductivity with a low price. The rationale behind the material selection criteria was to get a material that will resist the internal heat of the machine that will escape into the environment, and also to get a very hard material that will take years before it fractures [7]. The CES software was then used to determine the right material for the given purposes. Thermal conductivity was plotted on the y-axis against the price of the material in Ghanaian Cedi. The outcome of the graph was that lead alloys and stainless steel had a better thermal conductivity with a very moderate price as compared to the rest of the materials. To make a choice between these two materials, a further plot of hardness on the y-axis against price on the x-axis was done. From the graph, stainless steel had a very high hardness than the lead alloys. To further confirm this, non-linear force simulation was done in SolidWorks.

3.5. Design Specifications and Calculations

Average mass of maize grain = 0.72kg Bulk density = 591.630kgm³ [1] A bag of maize is 100kg.

From Density, $\rho = \text{mass} / \text{Volume}$, Volume, $V = \text{mass} / \rho = 0.72 / 591.630 = 0.0012199\text{m}^3$

If 1 is 0.00171698m³ then 100 will be 100 x 0.0012199m³ = 0.12199 m³.

For a given height of 700mm, the length of the square base will be $\sqrt{0.1299/0.7} = 0.430$ Hence the base was made from the dimension, 430 x 430 mm.

3.6. Amount of Heat to Effect Drying

$HD = C_a T_c MR$, where C_a is the air specific heat capacity which is approximately = 1.005 kJ/kg°C

MR is the amount of moisture to be expelled, which is approximately = 22.29kg

T_c is the temperature difference between the environment and the heating chamber, 43- 32°C = 11 degree Celsius.

$$HD = 323.469kJ$$

Hence, a heater that can produce almost 324kJ of heat is used [3].

3.7. Power Needed by the Motor for Operation

The power needed for rotation the agitating/stirring shaft with full load (P_{ps}) is as follows: $P_m = \text{Torque} \times \text{Angular velocity of shaft}$

But

$$\text{Torque } (\tau) = \text{total weight} \times \text{radius of the shaft. } (\tau_w) = (W_c + p_s + s_p) \times b_{sp} \quad (30)$$

where, $m_a = \text{Weight of maize} = 140 \text{ N}$.

(Using a higher threshold as a safety measure). $s = \text{Weight of stirrer shaft} = 70 \text{ N}$.

$R_s = \text{Radius of shaft} = 0.100 \text{ m}$.

$$\text{Torque} = (140 + 70) \times 0.100 = 21 \text{ Nm}$$

$$\text{Angular Velocity } (\omega) \quad v/r = N$$

$\times 6$ where, = Speed of stirrer shaft in rpm (set to 2.5 rpm =)

$$\omega = (2.5 \times 6) = 15 \text{ rad/s}$$

$$P_m = 21 \times 15 = 0.315 \text{ kW the paddle/stirrer shaft [2]}$$

3.8. Non-Linear Simulation Procedure of Main Body

Simulation of the main body part was performed with SolidWorks to confirm that indeed the stainless steel is harder and better than the lead alloys. A non-linear simulation was done on the body using a Solid type of Mesh. The selected body part was locked to hinges by four Jacobian points which consists of the top, bottom, right and left faces of the selected body. A resultant force of 560N was applied to the outer face when the material was made of lead alloys, and another one with the same simulation specifications was done with stainless steel as the material. The simulation was then run for 11 seconds to see the results.

3.9. Static Simulation of the Inner Lining of the Heating Chamber

A static simulation of thermal effect was performed with SolidWorks on the glass lining inside the inner part of the chamber. At first, a fiber glass of thickness 3mm was used in the simulation. All the four side faces were locked and a temperature value of 120 degree Celsius, which is twice more than the temperature at which the maize is likely to dry, was applied on the surface. The same procedure was used on a fiber glass with thickness of 10mm and the results from both simulations were observed.

3.10. Methodology in Building the Sensor Circuit

The circuit was built using an Arduino Uno R3 and a DHT sensor to read the temperature and moisture content level. In Arduino IDE, the code was written such that the user is alerted when the moisture content approaches 0. When the maize is put inside the chamber and the machine is started, the circuit switches on and the DHT reads the moisture content and temperature values at the onset of the operation. The moisture content and temperature values are then printed on a screen every 3 seconds. If the moisture content value is left with about 10 %, the message “Maize almost dry, moisture content is ‘X’%, Temp. = ‘Y’%” is printed. X and Y refer to the values at any given time within that range. Finally, when the moisture content is zero, the message “Your maize is dry, remove from chamber” is printed.

3.11. Mode of Operation of the Machine

Immediately the machine is switched on, the blower, the sensor circuit and the electric motor starts. When the motor starts, the gear on the motor has small teeth as compared to that on the agitator. Hence, there is a very large gear ratio produced which triggers the agitator gear and the agitator itself. The rotation automatically causes the shaft or the agitator to rotate at a very top speed as both are linked with the gears. The breadth of the spikes of the agitator is well calculated (5mm less than the breadth of the machine) to prevent the spikes from touching the inner lining of the chamber (fiber glass) to prevent it from frictional effect, and tear and wear of the machine. The agitator’s movement continuously stirs the maize to ensure that the heat is evenly distributed as they are being dried from the air and heat supplied by the blower. In the blower, a centrifugal fan blows on some heating elements within it to produce heated air. This kind of air picks up the moisture from the grains in the heating chamber and expels it in the surroundings through the perforated top. This process continues until the humidity and temperature sensor placed in the bottom of the design senses the moisture content is getting close to 0 and the

temperature within the chamber has also exceeded 43°C. If the moisture content value is left with 10 %,the farmer is prompted as a message is printed on the screen. Finally, when the moisture content is zero, the message “Your maize is dry, remove from chamber” is printed. The humidity and the temperature are displayed on the screen on the top left corner of the front view. This will prompt the farmer to manually turn off the machine, open the outlet, which is closed with a sheet of metal, and collect the grains.

3.12. Functionality and Implication of Design and Simulation

1. The top of the machine was perforated to prevent the moisture from accumulating in the chamber to ensure a faster and uniform drying
2. Inner lining of chamber was made of a fiber glass to prevent conduction from taking place and for energy conservation.
3. The fiber glass (lagging material) lining in the chamber was simulated to find the right thickness that can withstand the maximum heat that will be generated in the chamber.
4. The body and the agitator were made of stainless steel because it costs less, has a very high hardness to resist fracture and has a moderately low thermal conductivity.
5. Sensors were used to determine when the grains are fully dried and prevent overheating of it.
6. Right size of heater used to ensure energy conservation.
7. Bearings used to firmly hold the rotating agitator made of stainless steel at both ends to prevent the agitator from swinging while stirring the grains.

4. Results and Discussion

In this section, the results of the various aspects of the project are discussed.

4.1 Material Selection

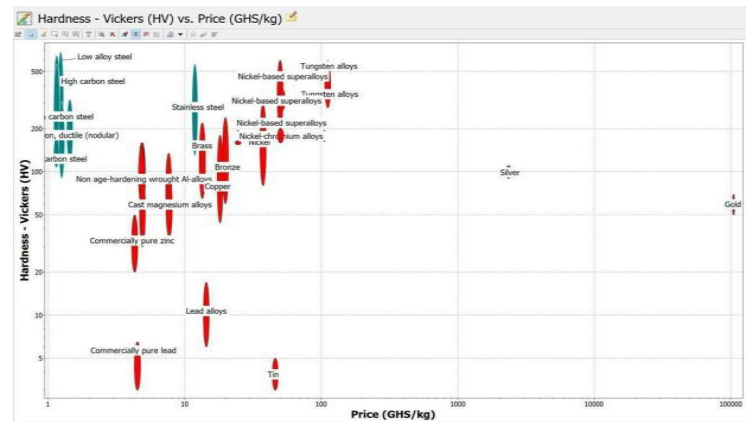
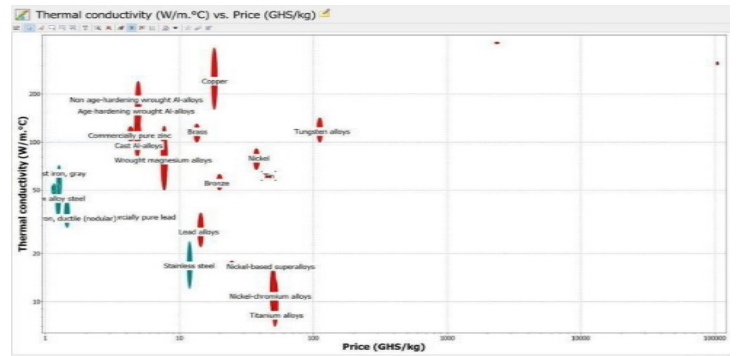

Figure 1: CES Graph

From Fig 1, it can be seen that in terms of hardness, low thermal conductivity and low cost, stainless steel appears to be better than the lead alloys. This means that the stainless steel can resist high forces to prevent deformation and with the low conductivity level, it will absorb no or minimal heat from the system. Fig 2-5 also shows the different views of the maize dryer designed using SolidWorks.

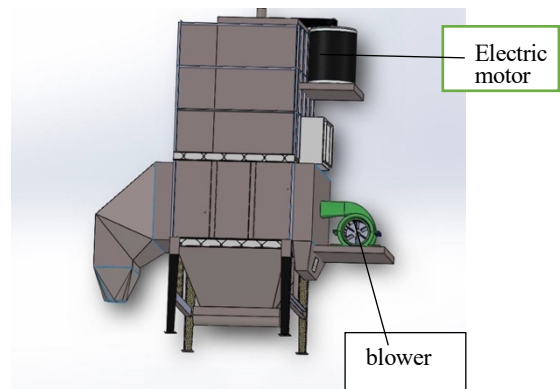

Figure 2: Side view of the Maize Dryer

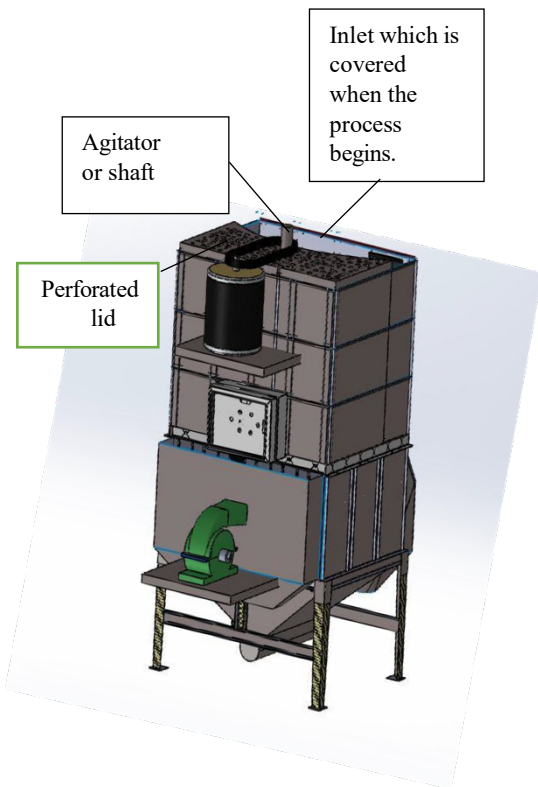

Figure 3: Isometric view of the Maize Dryer

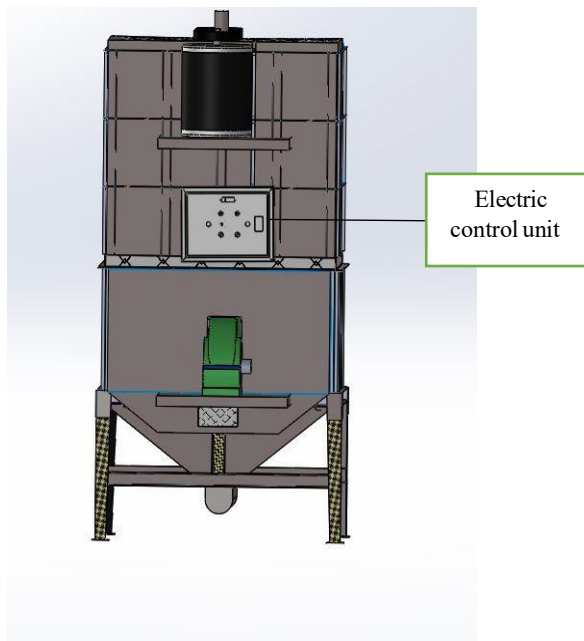

Figure 4: Back view of the Maize Dryer

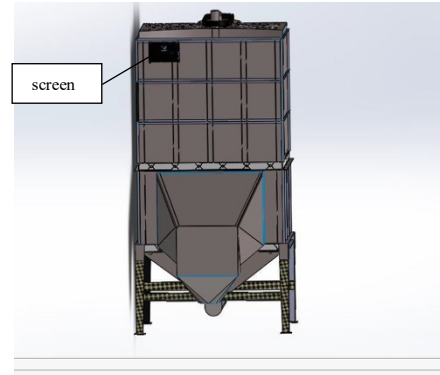

Figure 5: Front view of the Maize Dryer

4.2 Simulation of Main Body Part

Figures 6 and 7 show the results from the non-linear force simulation in SolidWorks performed on the main body part to choose the material that is hard, has low thermal conductivity and a low price. The simulation was done for both stainless steel and lead alloys. After locking the four edges face to hinges and applying a force of 560N on the part, the stainless steel was able to resist fracture and deformation to a larger extent as compared to the lead alloys. It was, therefore, clear that the lead alloy is very weak and cannot withstand higher number of forces applied in any direction. The stainless steel was therefore used in the final design.

4.3 Simulation of Fiberglass

Figure 8(a) shows the resulting deformation effect from the SolidWorks simulation of the lagging material, fiber glass with a thickness of 10mm. The applied heat temperature, 120°C was used. This temperature is twice more than the required temperature. Such temperature was used to monitor the worst-case scenario that can occur and lead to the failure of the machine. After applying thermal heat of 120°C (393 K) on one side of the glass, it was observed there was no deformation on the glass. It stayed as strong as without any heat applied. But for the glass in Figure 8(b), which had a thickness of 3mm, there was a total deformation. Hence, the final design had a fiber glass of thickness 10mm as the lagging material.

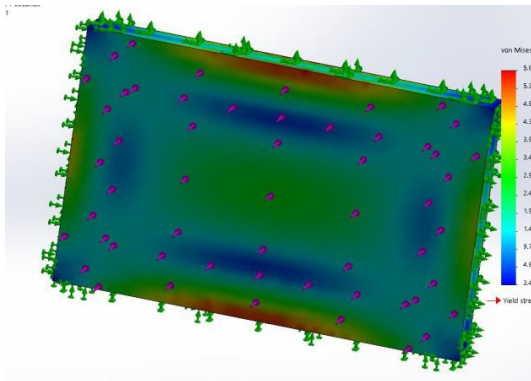

Figure 6: Lead alloy

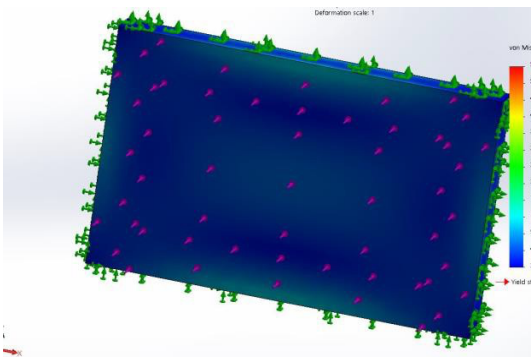
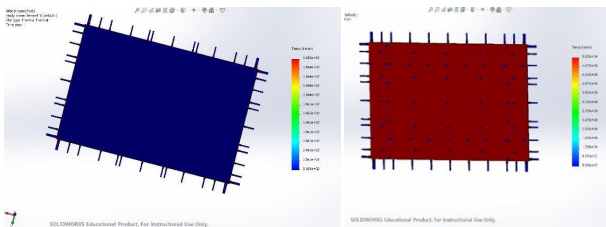

Figure 7: Stainless steel



(a)

(b)

Figure 8: (a) 10mm Fiberglass. (b) 3mm Fiberglass

4.4 Function of the Induction Motor

The shaft placed in the center of the cylinder is meant to guarantee even spread of the heated air in the cylinder due to its stirring motion together with its branch-like extensions at either side. This shaft is driven by an induction motor.

4.5 The Design and Operation of the Motor

This motor is designed using the Direct On- Line method of starting with only forward controls as that is all

that would be needed. With this method, there was the application of full line to line voltage at the start. The motor was then operated by controlling the energizing and de-energizing of the motor coils. When the start button is pushed, the coil becomes energized, the normally open contacts close and allow current to flow through them. The motor keeps functioning after the push button is released because the auxiliary contact is engaged when the start button is pushed initially. To switch off the motor, the stop push button is pushed and the coil de-energizes and all the contacts open once again thereby causing the motor to go off. This method of starting motors is best used for a smaller motor application. Since this maize dryer is being designed for small scale farmers and there are not much control requirements, the direct on-line method is ideal due to its simplicity [8]. Thermal relays and fuses are also employed in the design for protective purposes but are not seen in Figure 9 schematic due to the limitations of the software used.

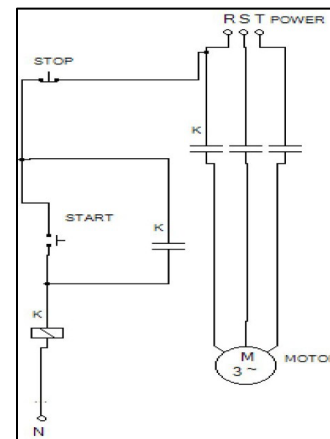

Figure 9 : Design schematic of the induction motor

4.6 Operation in Conjunction with the Shaft

The power source of the motor is the same source from which the main heating element and the blower get their power from. Once the main power is switched on, the heat exchanger and the blower immediately start operation. The start button of the motor is then pushed after a few minutes to begin agitation of the shaft and to enable even circulation of the heated air.

4.7 Simulation of Sensors

The sensors to determine the temperature and moisture content in the chamber were programmed in Arduino as shown in Fig 10.

```

DHT_sensor_for_maize_dryer §
1 // intialisation of DHT sensor
2 #include "DHT.h"
3 #define dht_1 2
4 #define DHTTYPE DHT11
5 DHT dht(dht_1, DHTTYPE);
6
7 void setup() {
8   Serial.begin(9600);
9   dht.begin();
10  delay(2000);
11  //Initial readings when maize is placed in chamber
12  float humid = dht.readHumidity();
13  float temp = dht.readTemperature();
14
15  Serial.print("Initial conditions of chamber");
16  Serial.println("Moisture content(chamber)= ");
17  Serial.println(humid);
18  Serial.println("temperature(chamber)= ");
19  Serial.println(temp);
20  Serial.println("°C");
21
22 }
23
24 void loop() {
25   delay(2000);
26   //condition for dry maize
27   if (humid < 1.0 && humid > 0.0) {
28     Serial.print("Maize is dry, remove from chamber");
29     Serial.println("Moisture content(chamber)= ");
30     Serial.println(humid);
31     Serial.println("temperature(chamber)= ");
32     Serial.println(temp);
33     Serial.println("°C");
34   }
35
36   // condition for when maize is almost dry
37   else if (humid <= 10.0 && humid >= 1.0) {
38     Serial.print("Maize almost dry");
39     Serial.println("Moisture content (chamber)= ");
40     Serial.println(humid);
41     Serial.println("temperature(chamber)= ");
42     Serial.println(temp);
43     Serial.println("°C");
44   }
45   else {
46     Serial.print("Maize not dry yet")
47     Serial.println("Moisture content = ");
48     Serial.println(humid);
49     Serial.println("temperature= ");
50     Serial.println(temp);
51     Serial.println("°C");
52   }
53 }

```

Fig. 10: Arduino code for sensors built with Proteus

5. Conclusion and Future Work

As was discussed, the CES software helped in settling on which material to use for the design. The material selection was pivotal as the success of the simulation is dependent on the material chosen. From the simulations, it was observed that Stainless Steel was better resistant to the force which was applied to it as compared to Lead alloy thus was chosen. The simulation for the fiber glass proved that the 10mm thickness was more desirable. Adopting the maize dryer would improve the financial gains of the farmers as it would reduce post- harvest losses of their crops. For future works, integrating machine

learning models into the system will help to predict when the maize will dry even before the process is started. This will go a long way to save time in supervision of the drying process.

Acknowledgement

A very special thank you to Mr. Richard Akparibo and Emmanuel Asare for their encouragement and advice in making this project a success.

References

- [1] B. Fashina , A. Olanrewaju, and A. Sanusi. (2013). Design parameters for a small-scale batch in-bin maize dryer. *Agricultural Sciences*. 04. 90-95. 10.4236/as.2013.45B017.
- [2] E. O. R. Ayodele, "Design and Construction of Electric Corn Dryer," 2016.
- [3] M. A. C. Purio, J. D. P. Matanguihan, S. K. R. Peña, G. M. V. Principe and E. J. T. Tabada, "Solar-Powered Paddy Grain Humidifier-Dryer," 2016 IEEE Region 10 Conference (TENCON), Singapore, 2016, pp. 3414-3419, doi: 10.1109/TENCON.2016.7848688.
- [4] S. S. Hidayat, A. Suharjono, T. Prasetyo, Jumi, A. Roihadin and A. S. Alfauzi, "Development of Two-In-One Type Drying Machine and Grinder Control System Based On Wireless Sensors Network," 2018 International Conference on Applied Science and Technology (iCAST), Manado, Indonesia, 2018, pp. 750-753, doi: 10.1109/iCAST1.2018.8751611.
- [5] Y. Jin, Z. Zhang, D. Yang, H. Zhang and J. Yin, "Design of A New Type Horizontal Rotary Drying Chamber," 2021 International Conference on Intelligent Transportation, Big Data & Smart City (ICITBS), Xi'an, China, 2021, pp. 270-273, doi: 10.1109/ICITBS53129.2021.00074.
- [6] Timothy, V.O, Adegbenro and K.R., Saliu, "Development of maize - on - cob- dryer for small scale farmers. *Scientia Agriculturae*," 2016, 172 - 178. 10.15192/PSCP.SA.2016.14.1.172178.
- [7] M. Kriang-Krai, "Mobile maize dryer development at farm and cooperative/collector levels," 2015.
- [8] K. Stanislav, O. Petr and P. Pavel," Simulation of Start-Up Behaviour of Induction Motor with Direct Electronic Engineering," 2018, 15. 10.15598/aeee.v15i5.2342.