

Design, Fabrication and Testing of a Torsional Compression Thread-based Gari Screw-type Press (Cassava Pulp Mechanical Dewatering Machine)

Daniel Amoshie ¹, Marshall Dzwene ², Munashe Nyazenga ³ and Simbarashe Tanyanyiwa ⁴
Engineering Department, Ashesi University

¹ Electrical Engineering; daniel.amoshie@ashesi.edu.gh

² Electrical Engineering; marshall.dzwene@ashesi.edu.gh

³ Computer Engineering; munashe.nyazenga@ashesi.edu.gh

⁴ Electrical Engineering; simbarashe@ashesi.edu.gh

Abstract: Gari is a popular type of food in Africa obtained from the dry frying of dewatered cassava pulp. Unfortunately, small scale Gari producers in Africa are hampered by adoption of inefficient and inappropriate pressing methods. This delays Gari production and results in low quality products. The purpose of this study is to design, fabricate, and test a torsional thread-based cassava pulp mechanical dewatering screw press which will provide a cheaper way of pressing cassava compared to the modern methods which are too expensive for the ordinary farmer due to the complexities involved in their processes and the components used in manufacturing them. The aim is to make a more hygienic system by enclosing the cassava pulp in a confined cylindrical space and providing a way of trapping the liquid emanating from the compressed cassava pulp during pressing. The screw will make it easy to drive and press the cassava pulp. The research also gives details of the manufacturing processes, tools, materials, that will be used if the product is fabricated. Cassava was not utilized in the testing process, rather, a wet napkin to test the pressing mechanism by reducing its moisture content. It was found that the machine could dewater 2 kg wet a napkin with 70 % to 15 % moisture in about 3 minutes. The maximum stress reported on the screw shaft handle was 2.773×10^7 N/m² which was less than the yield strength of the material used for the simulation.

Keywords: Dewatering, Cassava, Press, Gari, Torsional, Ferritic

1. Introduction

Gari, the most commercialized cassava product in Ghana, continues to increase in production due to the increasing urban demand and export market potential [1]. Cassava is a plant that originated in South America but is now grown in most African countries [2]. Small-scale Gari processing methods in Ghana are primarily traditional, leading to a limited range of finished products from cassava [3]. Old and inefficient local gari pressing methods are time-consuming (taking up to 4 days or more), less hygienic, and result in poor/low product yields. Existing methods need to ensure product quality consistency or scale economies [3].

Current dewatering operation is mainly carried out manually in rural communities. One of the approaches is a "twisting sack to effect dewatering" method, where the wet cassava mash is placed in a porous sack and manually twisted to squeeze out the excess water [4]. Another approach is placing a "heavy stone on top of mash sack," where wet cassava mash is put inside a porous sack, and a heavy stone is placed on top of the sack to press out the excess water [4]. These methods are labor-intensive and time-consuming, especially for large-scale production.

Additionally, modern methods are too expensive for the ordinary farmer due to the complexities involved in their processes and the components used in manufacturing them. An example is the design and fabrication of an electric motor driven press (cassava dewatering machine) by O.P. Akinmolayan et., which uses an electric motor and

a screw press where cassava mash is fed into a hopper, and the screw press applies pressure to the mash, forcing the water out through the perforations on the press. The narrow range of processed products and poor processing technologies could also affect the commercialization of the crop in Africa [3].

Based on the challenges with current approach to gari dewatering, this project therefore aims to design, fabricate, a mechanical gari dewatering system which will provide a cheaper way of processing cassava. Another goal is to create a more sanitary system by enclosing the cassava in a confined cylindrical space and providing a method of trapping the liquid emitted from the compressed cassava pulp during pressing to make the whole process more hygienic. The research gives details of the manufacturing processes, tools, materials, that will be used if the product was to be fabricated. Cassava was not utilized in the testing process, rather a wet napkin to test the pressing mechanism by reducing its moisture content.

2. Equipment and Methods

One of the top priorities of this research study was to identify the best material for making the gari press. Several factors were considered when deciding on the materials that will be used to construct the gari press. Such factors include mechanical strength, corrosion resistance, impact resistance, and cost.

2.1. Equipment

In this study, SolidWorks 2019, was used to design and perform mechanical analyses on the desired solution concept. The scrap materials used in making the low fidelity prototype of the desired solution concept were obtained from Kumasi, Ghana. Microsoft Excel was used to plot graphs the collected data, for further analysis.

2.1. Methods

2.1.1. Brainstorming

Several solution ideas were generated during a brainstorming session to address a problem. Sketches were drawn to conceptualize the designs. Four design ideas were presented. The first design idea was a hydraulic jack gari press, which would use a hydraulic cylinder on a sliding piston to force liquid out of cassava pulp as shown in Figure 1a. The second design was an electric motor drive press, which would lower a pressing lid slowly to press liquid out of the cassava pulp using an electric motor and gear as shown Figure 1b. The third design was a torsional compression thread based gari screw-type press, which would use a thread connected to a handle to press cassava pulp and force liquid out through perforated holes as shown in Figure 1c. The fourth design was a centrifugal press, which would rotate cassava pulp at high speed to separate it from liquid using centrifugation shown in Figure 1d.

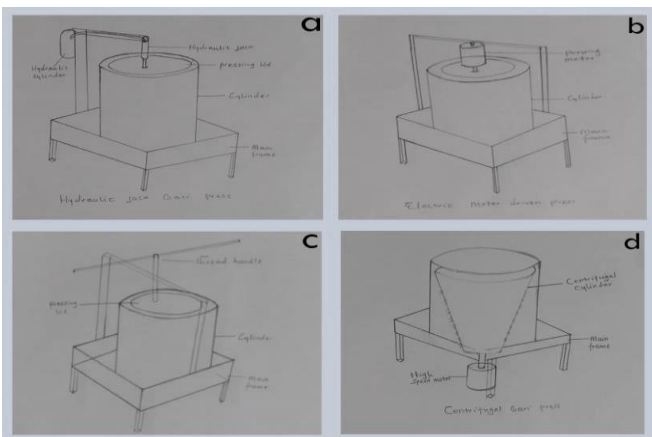

Figure 1: (a, b, c, d) show the four sketches of the design solution ideas for the identified problem (hydraulic jack gari press, electric motor driven press, torsional compression thread based Gari Screw-type Press, centrifugal press)

2.1.2. Selection

After evaluating the different concepts from the brainstorming session, a torsional compression thread based Gari Screw-type press was selected the final design solution. This design was chosen for its numerous benefits. Firstly, this type of press applies torsional force to compress the cassava pulp, which is highly effective in removing excess water and ensuring high-quality Gari. Secondly, the screw-type press allows the cassava pulp to be confined in a cylindrical space during pressing, resulting in a more hygienic process that reduces the risk of contamination. The screw also simplifies the process of driving and pressing the cassava pulp, which is important for small-scale Gari producers.

Furthermore, the torsional compression thread-based Gari screw-type press is more cost-effective than modern methods that involve complex processes and expensive components. This makes it a more viable option for small-scale Gari producers in Africa who may have limited financial resources. In summary, the torsional compression thread-based Gari screw-type press is the best design for Gari dewatering due to its effectiveness, hygiene, ease of use, and cost-effectiveness.

The prototype was designed to take a load of about 20KN. Since load is transmitted under compression, the screw was made from Ferritic Stainless steel with yield stress of 200 N/mm. The screw was subjected to the equation given by,

$$Load (W) = \frac{A_s \times \delta_y}{F S}$$

Where W is load, A_s is the area of screw, δ_y is yield stress and $F S$ is the factor of safety.

$$20000 = \frac{\pi d_s^2 \times 200}{4 \times 2} \text{ at } F S = 2$$

$$d_s = 15.96mm$$

This informed the choice of screw diameter for building.

2.1.3. SolidWorks Engineering Design

2.1.3.1. 3D Isometric

As mentioned earlier, *SolidWorks* 2019, was used to design the torsional compression thread based Gari Screw-type press. The *SolidWorks* design is shown in Figure 2 below.

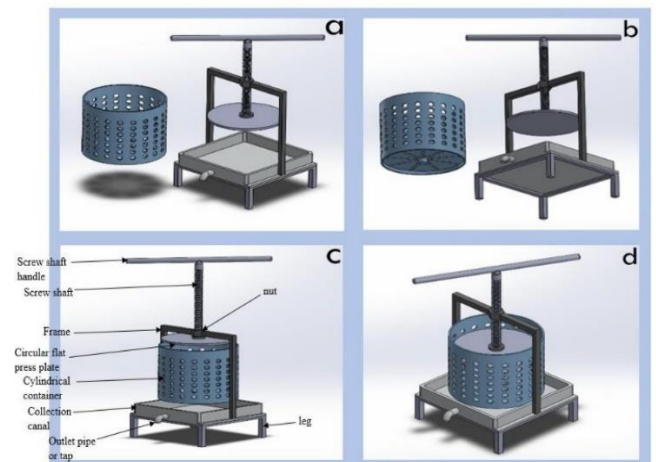

Figure 2: Shows the *SolidWorks* Design of the Gari Press (a-b) 3D Views of the Different Components of the Press (c) Exploded View of the Gari Press (d) Fully Assembled Gari Press

2.1.3.2 Third Angle Autographic view

The fully assembled *SolidWorks* Design of the Gari Press by dimension (See Figure 2), can be put in a box with a vertical height of 723.41 mm, a horizontal width of 350 mm and a horizontal length of 370 mm. The cylindrical container has a diameter of 300 mm and a height of 280.78 mm, while the circular plate connected to the central screw shaft has a diameter of 280 mm. The frame with the mid-

joint nut for the screwing system has a vertical height of 427.50 mm and is 30 mm above the cylinder to give room for screwing. The cylindrical container has circular perforated holes (10 mm in diameter) which allow liquid from the cassava pulp to seep through during mechanical compression into the collection canal. The collection canal is large enough (370 mm by 350 mm by 50 mm) to hold the liquid emanating from the compressed cassava through the perforated holes for a while as it flows out through the connected outlet tap (10 mm in diameter). The screw shaft handle (12 mm thick) is what will provide the required torsional force to drive and press the cassava pulp.

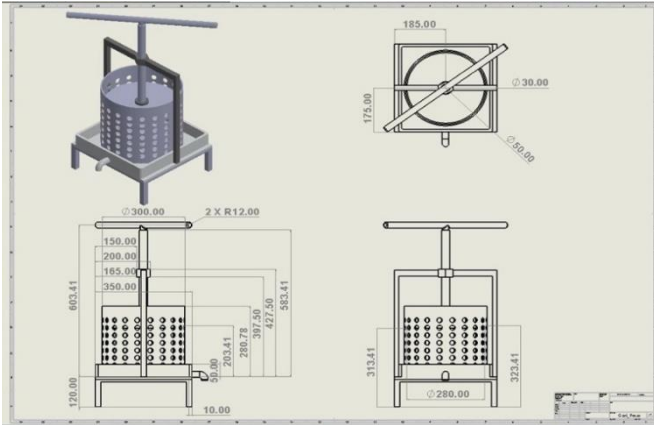

Figure 3: Shows the 3rd angle autographic projection with all detailed drawings and dimensions in mm.

2.1.4 Cost Analysis

Before prototyping and simulation, a cost analysis of the gari press was conducted to determine the total amount required to make the gari press by breaking down the costs into unit costs of the respective part's dimensions and material type.

Table 1: Cost analysis for the Gari Press

Part	Dimension (±0.02 ~0.03)	Material Type	Unit Price (\$)	Cost (\$)
Frame (40 × 40mm square tubes)	1.70 m length, 0.04 m thickness	Ferritic Stainless Steel	4.57/m	7.77
Flat circular press plate	0.3 m outer radius, 0.03 m thick	Ferritic Stainless Steel	10.99/kg/m	10.99
Screw shaft	0.05 m radius, 1m height	Ferritic Stainless Steel	1.94/m	1.94
Perforated Cylindrical Container	0.3m inner radius, 0.84 m height	Ferritic Stainless Steel	11.21/m	11.21
Outlet Pipe/Tap	0.05 m thickness	Brass	9.35	9.35
Total Cost			38.06	41.26

2.1.5. Mechanical Simulation

Selective simulations were performed on the Gari Press. A mechanical simulation was conducted on the frame with the mid-joint nut for the screwing system and the screw shaft handle (See Figure 2). It was necessary to determine the response of the screw shaft handle and the frame with the mid-joint nut for the screwing system when an equivalent torsional force of 120 N was applied during the screwing process on the Gari Press. Quantitative stress data was then obtained from the simulated results by probing across the screw shaft handle, near the joint.

2.1.6. Prototype Fabrication

A prototype of the Gari Press was fabricated to mimic the 3D model presented earlier in Figure 2. Parts were welded together. Major parts used include a cylindrical container, screw shaft, round bar, metal plate, nut, and square tubes.

3. Results & Discussion

3.1. Mechanical Simulation

From the simulation conducted on the T-shaped screw shaft of the gari presser, assuming a torsional force of 120 N, the maximum stress reported on the screw shaft handle was $2.773 \times 10^7 \text{ N/m}^2$. This strength was less than the yield strength of the material used for the simulation (ferritic stainless steel) $\sim 1.723 \times 10^8 \text{ N/m}^2$, which implies that under static torsional loading, the T-shaped screw shaft of the gari presser (made from ferritic stainless steel) would sustain the applied force without plastic deformation. Therefore, it would not yield due to any evidence of permanent plastic deformation, which leads to failure. Quantitative stress data was also obtained from the simulated results by probing across the screw shaft handle near the joint (Figure 4a). The graph (Figure 4b) suggested higher stresses near the joint where the screw shaft connected with the screw shaft handle. Stress distribution was found to increase from $2 \times 10^6 \text{ N/m}^2$ to $1.25 \times 10^7 \text{ N/m}^2$.

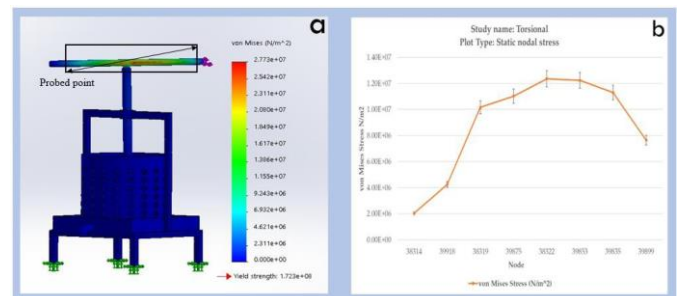

Figure 4:(a) Qualitative Model of the Simulation of the Gari Press after applying a Torsional Force of 120 N and (b) Quantitative Data Obtained from probing across screw shaft handle near the joint shown in (a)

An upward reaction force was then induced on the circular press to counter the net downward force, and to determine the response of the frame with the mid-joint nut for the screwing system. The maximum stress reported on the frame with the mid-joint nut was $2.348 \times 10^6 \text{ N/m}^2$ which

is less than the yield strength of the material used for the simulation (ferritic stainless steel) $\sim 1.723 \times 10^8 \text{ N/m}^2$. Quantitative stresses near the fixing point, where the threads flashed with the middle nut. Stress distribution was found to increase from $1 \times 10^5 \text{ N/m}^2$ to $2.1 \times 10^5 \text{ N/m}^2$. However, the result was reduced at the midpoint of the screw, halfway between the two points where the threads flashed with the middle nut, to a value of about $1.55 \times 10^5 \text{ MPa}$.

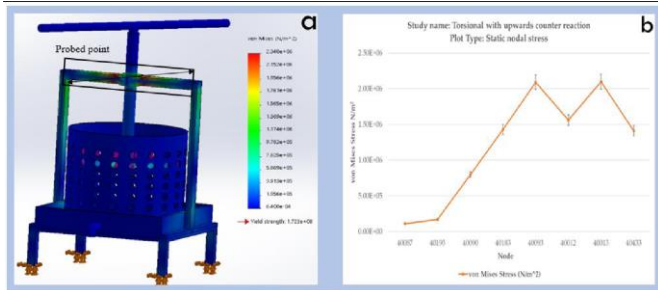

Figure 5: Qualitative model of the simulation of the gari press after applying a torsional force of 120 N and an upward reaction force was then induced on the circular press to counter the net downward force (b). Quantitative Data Obtained from probing across the frame with the mid-joint nut for the screwing system shown in (a)

3.2. Manufacturing Process

The design is quite simple. The joints in the frame are welded, first to the nut in the middle, then to the main four-legged frame. The T-shaft screw with a welded handle is then screwed into the mid-joint nut with a circular press plate attached to its bottom that easily fits into the cylindrical container, which is welded as part of the main four-legged frame. The curved surface of the cylindrical container is perforated to allow collection of drained fluid emanating from the compressed cassava pulp into the collection channel, then out through an outlet pipe to trap the liquid for other uses. The cylindrical container is welded from beneath, to hold cassava during the pressing process. **Tools required:** Spare parts – None; Fuel Type – None; Pressure Source – Screw. **Materials:** Ferritic Stainless steel for the whole design and Brass for the outlet pipe or tap.



Figure 6: (a) Prototype of the torsional compression thread-based gari screw-type press (cassava pulp mechanical dewatering machine)

4. Conclusion

From this project, it was found that a mechanical dewatering screw press provides a cheaper way of processing cassava compared to modern methods. Also, it was discovered that the moisture content of cassava pulp is dependent upon the pressure applied, volume of cassava, and mass of cassava which are parameters that can be considered for further research. However, further research should be done on how to increase the quantity of gari that can be produced from cassava per batch.

One of the major lessons learned was the procedure for selecting the suitable materials by considering their mechanical properties. Simulation and 3D modeling prior to fabrication proved to be of high importance when it comes to working with different materials to produce a final product. Stainless steel was selected based on its BCC structure (high tensile strength) and its moderate ductility, derived from solid solution strengthening and strain hardening. Stainless steel was also selected due to its excellent resistance to corrosion, weldability, and its relative cheapness. discovered that chromium is what makes stainless steel stainless. Chromium is also a ferrite stabilizing element. Chromium causes the austenite region to shrink, while the ferrite region increases in size.

Acknowledgments

Much appreciation and thanks go to Dr. Danyuo Yiporo and Mrs. Miriam Abugre, our project supervisors, for their unwavering support throughout this project.

References

- [1] Oduro I., Ellis, W. O., Dziedzoave, N. T., & Nimako, Y. K. (2000). "Quality of gari from selected processing zones in Ghana," Food Control, vol. 11, no. 4, pp. 297–303, Aug. 2000, doi: 10.1016/S0956-7135(99)00106-1.
- [2] Olusegun, H. D. & Ajiboye, T. K. (2009). The Design, Construction and Testing of a Vertical Squeeze Cassava Pulp Dewatering Machine. Journal of Applied Sciences Research, 5(10): 1285-1297
- [3] Akinmolayan, O., Anjorin, S., Odunfa, K., Akintan, E., & Ajayi, O. (2018). The Design and Fabrication of an Electric Motor Driven Press (Cassava Dewatering Machine). Retrieved from <https://imeetmcon.com.ng/wp-content/uploads/2019/08/44.pdf>.
- [4] Kolawole, O.P., Agbetoye, L.A.S., & Ogunlowo, A.S. (2011). Evaluation of cassava mash dewatering methods. Journal of Bioinformatics and Sequence Analysis, 3(2), 23-30. Available online at <http://www.academicjournals.org/JBSA> ISSN 2141-2464.
- [5] Oti, E., Olapeju, O., Dohou, S., Moutairou, E., Nankagninou, D., Komlaga, G. A., & Loueke, G. M. (2010). Training manual processing of cassava into gari and high-quality cassava flour in West Africa. Retrieved from <https://issuu.com/coraf/docs/cassava>
- [6] Okegbile, O.J., Hassan, A.B., Mohammed, A., Abdullahi, A.A., & Jimoh, D.S. (2017). The design of a pedal-driven pulverizing and sieving machine for dewatered grated cassava. International Journal of Engineering Research in Africa, 32, 14-23.