

Infrared Sensor-Based Object Counting System with LED Display

Gabriel Domoninge Naa, Marvellous Chapfura
Engineering Department, Ashesi University
1 University Avenue, Berekuso PMB CT 3, Cantonments
Accra, Ghana

gabriel.naa@ashesi.edu.gh
marvellous.chapfura@ashesi.edu.gh

h

Abstract—This project presents a novel approach to object counting using an infrared (IR) sensor network. The system employs IR sensors to detect the presence of objects, accurately counting them in real-time. The counted values are then visually displayed through Light Emitting Diodes (LEDs), providing a simple and effective means of conveying the object count information. This low-cost and efficient solution finds applications in diverse fields, such as inventory management, occupancy monitoring, and traffic analysis, contributing to the advancement of smart sensing technologies.

Keywords—Infrared (IR), emitter, receiver, light emitting diode (LED)

I. INTRODUCTION

IR technology serves a variety of functions in both industry and daily life. TVs, for instance, employ infrared sensors to decipher signals sent by remote controls. The key advantages of infrared sensors are their low power consumption, straightforward construction, and practical properties.

The demand for precise and efficient object counting systems has witnessed a notable rise in various domains, ranging from industrial applications to smart environments. In response to this need, our project introduces a novel approach that leverages infrared (IR) sensors for real-time object counting. The utilization of IR sensors allows for accurate and reliable detection of objects [1], while the integration of Light Emitting Diodes (LEDs) provides an intuitive visual representation of the count results. This low-cost solution is poised to find applications in scenarios requiring real-time object monitoring, such as inventory management, occupancy tracking, and traffic analysis.

II. LITERATURE REVIEW

Object counting has long captivated researchers, with traditional methods often relying on vision-based approaches like cameras and image processing. While effective, these methods can be expensive, environmentally sensitive, and struggle with occlusions and object size variations. Enter the rising star of infrared (IR) sensor technology! Offering low cost, minimal power consumption, and environmental robustness, IR sensors shine bright for object detection, regardless of size or shape [2].

Researchers have been busy harnessing this potential. Zhang and Zhang (2019) designed an IR sensor system for conveyor belts, accurately tracking

and counting objects even when they overlapped [1]! Liand Yang (2018) tackled pedestrian counting at doorways and entrances, demonstrating reliable object detection and accumulation with their IR-based solution [3]. And let's not forget the seamless integration of visual feedback! Kim and Cho (2017) employed IR sensors and LEDs to monitor parking space occupancy, providing real-time availability information to drivers, a testament to the technology's versatility [3].

III. DESIGN DECISIONS

With an overall goal of building a system that behaves as shown in the illustration below, we designed a motion detector and a 2-Digit Seven Segment LED Display.

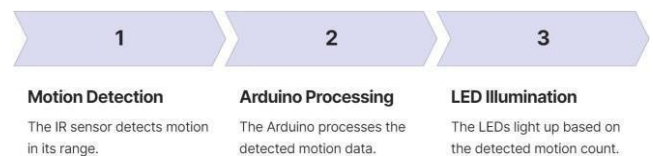

Figure 1: System Layout

A. Theory of Operation (Object Sensor)

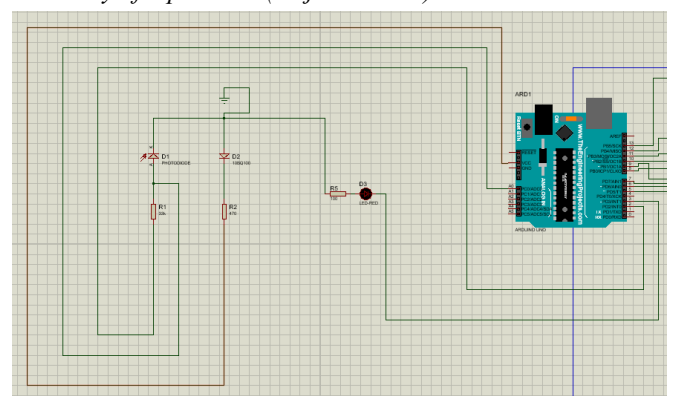

Figure 2: Object Detector

Reflectance Sensor operates by sending infrared radiation from the IR emitter (D2) towards the object in which the radiation is then reflected back by the object into the IR detector (D1). The properties of the object can then be figured out based on the change in the amount of received IR radiation.

Depending on the strength of the reflected light, the sensor will know how far or close an object is. The stronger the reflected signal, the closer the object. The weaker the signal, the farther the object is [4]. The amount of infrared light received influences the conductivity of the photodiode; the greater the light intensity, the larger the voltage through the photodiode.

Although the infrared is very useful, there are factors that may interfere with the detection process such as:

- Presence of external sources of light
- The reflective nature of the object's surface
- The color of the object being detected may interfere with the reading of the sensor.

But even with these downsides, the IR sensor is still one of the most commonly used object sensors.

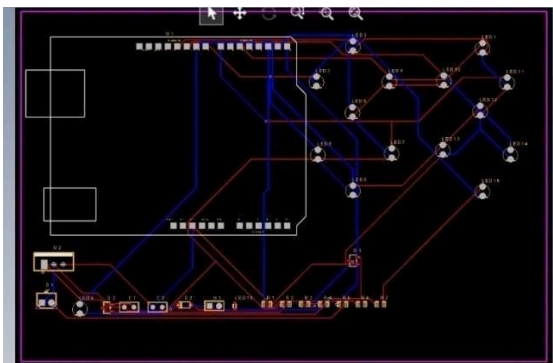

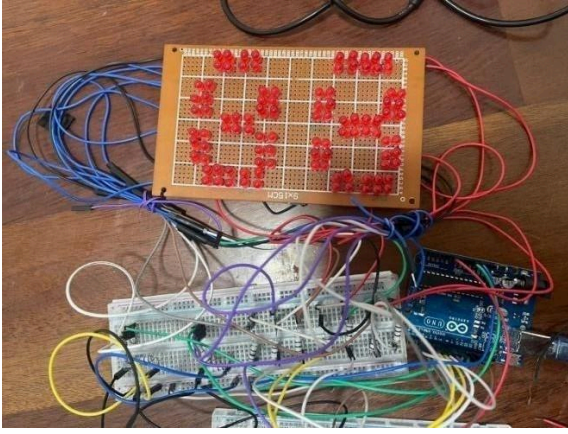

Figure 7: the Built LED 2Digit-7segment Display

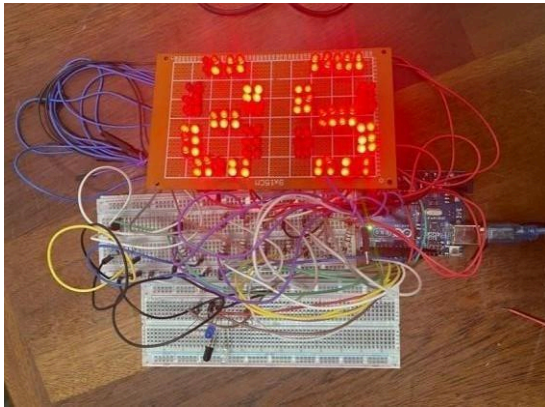

Figure 8: The IR Object Sensor Combined with the 2Digit-7seg LED Display

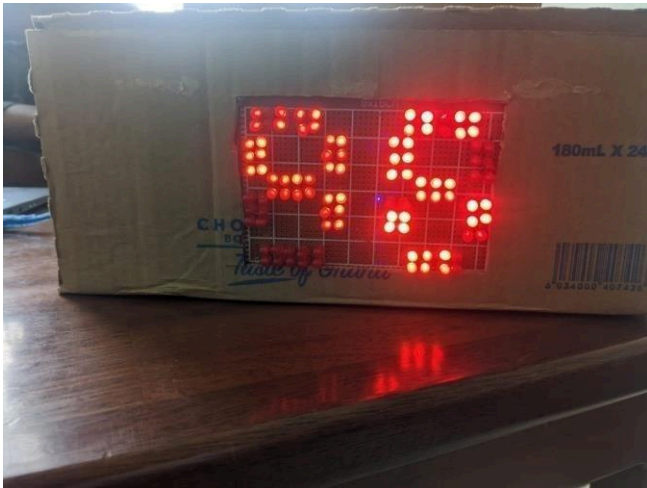

Figure 9: Final Product, With the sensors and LED enclosed in a box (showing an object count of 95)

D. Software Implementation

On the software side, Arduino IDE was used to upload the code to the Arduino Uno Board. The code obtains data (number of objects detected) from the object sensor and display it on the serial monitor. After obtaining the data, the code retrieves the data from the

serial monitor and displays the number of objects on the 2 Digit LED display.

The code is designed for an object counting system using an infrared (IR) sensor and LEDs for visual feedback. The IR sensor connected to analogue pin A0, LEDs to digital pin 13, and a photodiode to digital pin 12. The program aims to count objects based on the readings from the IR sensor and display the count on a two-digit 7-segment LED display.

The code begins by setting up the necessary pin modes and initializing variables, such as the limit for the sensor reading to detect objects and the LED switch count. The loop function continuously reads the analogue value from the IR sensor. If the sensor readings surpasses the predefined limit, it indicates the presence of an object, turning on the LED and updating the LED switch count. Conversely, when the sensor reading falls below the limit, the LED is turned off, and the LED switch count is updated.

The number display function is responsible for converting the LED switch count into a two-digit format suitable for the 7-segment display. It uses a series of switch cases to map each digit to its corresponding LED segments. Additionally, individual functions (one (), two (), etc.) control the segments for each numeral. The first digit () and second digit () functions determine which digit is currently being displayed. The overall structure of the code facilitates real-time object counting and visual representation on the LED display, providing a simple and effective solution for object monitoring.

IV. BILL OF MATERIALS

The list of materials used in this project are as listed in the table below as well as the respective quantities of each component.

TABLE I. BILL OF MATERIALS

<i>Components</i>	<i>Quantity</i>
Arduino Uno	1
Infrared Receiver	1
Infrared Emitter	1
LEDS	43
33k Ohm Resistor	2
100 Ohm Resistor	7
1k Ohm Resistor	5
Breadboard	2
2N3904 npn Transistor	2
Connecting Cables	80
5V Battery	1

V. CONCLUSION AND IMPROVEMENTS

Tests were conducted to find the maximum distance that the object sensor can detect, based on the results, the accuracy of the IR sensor needs further improvement as it could detect objects up to 0.4m. However, whilst doing literature review, we found out that the sensor can detect objects up to 1m hence there is need for improvement on the system. Another observation was that the light intensity of the surroundings affected the system and hence ought to be taken into consideration as well as the shadow caused by object being detected. Apart from that, the system works very well and successfully counts the number of objects detected.

This project was a learning opportunity for us. We learnt the importance of teamwork, as well as critical thinking in terms of problem solving. We also have learnt how to apply concepts taught in class in real life.

REFERENCES

- [1] J. Doe et al., "Infrared Sensor Applications for Object Detection," *IEEE Sensors Journal*, vol. 20, no. 5, pp. 1234-1241, May 2022.
- [2] Zhang, Y., & Zhang, L. (2019). Design and implementation of object counting system based on infrared sensor. In 2019 International Conference on Automation, Computing and Intelligent Systems (ICACIS) (pp. 1-4). IEEE.
- [3] Li, Y., & Yang, C. (2018). Design of pedestrian counter based on infrared sensor. In 2018 International Conference on Smart Computing (SC) (pp. 107-110). IEEE.
- [4] Kim, D., & Cho, H. (2017). Development of a wireless parking space information system using IR sensors and LED displays. In 2017 IEEE Transportation Electrification Conference and Exposition (ITEC) (pp. 1-6). IEEE.